

**IMPORTANT**  
 THIS DRAWING OR SPECIFICATION CONSTITUTES THE CONFIDENTIAL INFORMATION OF BRIG'S MACHINING CO. AND ITS RECEIPT OR POSSESSION DOES NOT CONVEY ANY RIGHT IN OR LICENSE TO USE IT OR THE INFORMATION DISCLOSED HEREIN NOR ANY RIGHT TO REPRODUCE THIS DRAWING OR SPECIFICATION NOR ANY PART HEREOF WITHOUT THE WRITTEN CONSENT OF BRIG'S MACHINING CO.

ZONE		REV	DESCRIPTION	DATE	APPROVED

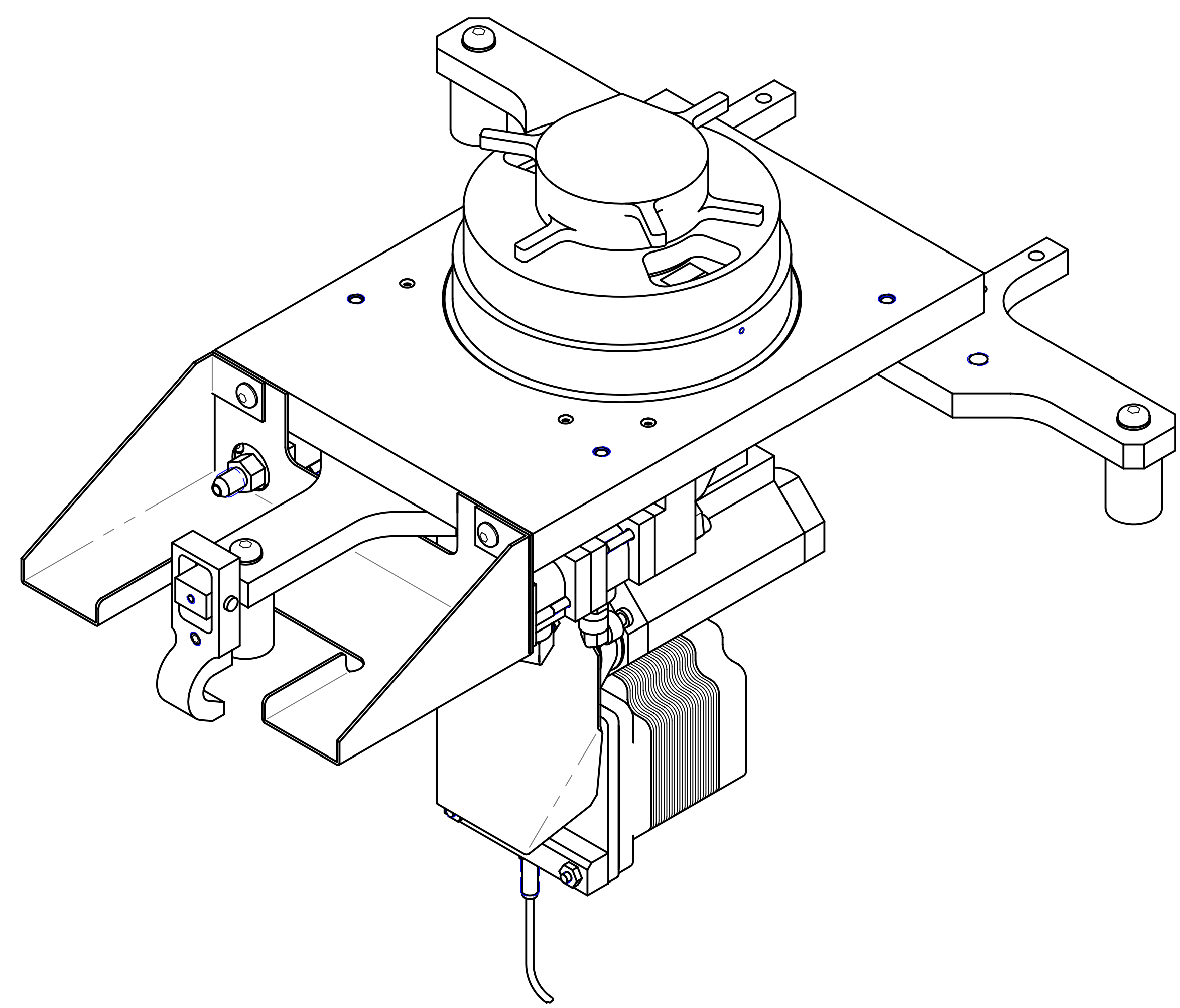
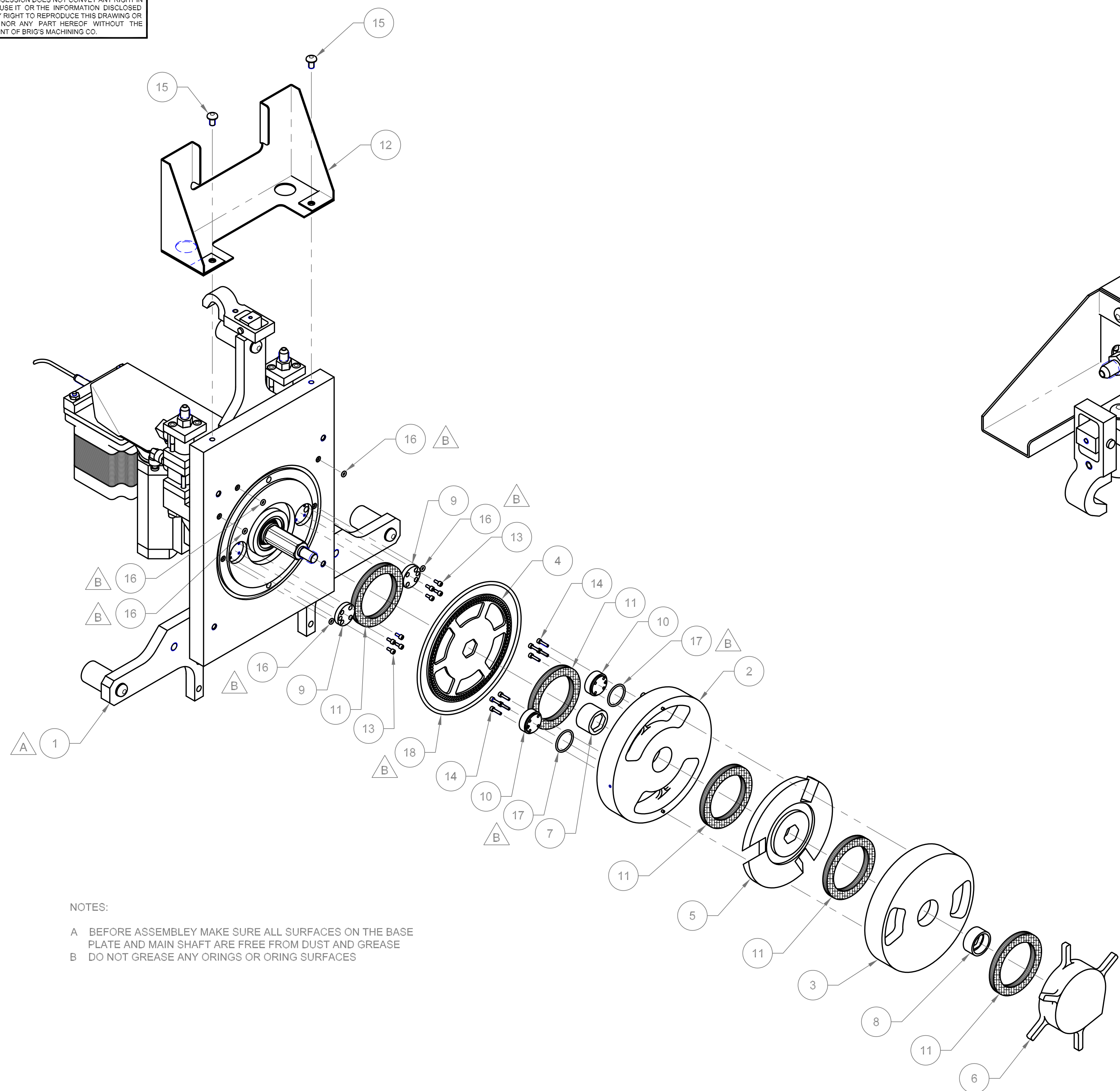

NOTES:  
 A BEFORE ASSEMBLY MAKE SURE ALL SURFACES ON THE BASE PLATE AND MAIN SHAFT ARE FREE FROM DUST AND GREASE  
 B DO NOT GREASE ANY ORINGS OR ORING SURFACES

ITEM	QTY	REGD	DWG SIZE	PARTY OR IDENTIFYING NO.	NOMENCLATURE OR DESCRIPTION	MATERIAL SPECIFICATION
18	1				75 VITON ORING SIZE 256	
17	2				75 VITON ORING SIZE 020	
16	5				75 VITON ORING SIZE 006	
15	2				1/4-20 STL BUTTON HEAD CAP SCREW x 3/8"	
14	8				4-40 STL SCOCKET HEAD CAP SCREW x 7/16"	
13	8				4-40 STL SCOCKET HEAD CAP SCREW x 1/4"	
12	1	D	171D-174		PINCH COVER	
11	5	A	171D-136		FELT SEAL	
10	2	A	171D-135		POWDER SEAL TOP	
9	2	A	171D-134		POWDER SEAL BOTTOM	
8	1	A	171D-145		LOAD WHEEL SPACER	
7	1	A	171D-144		FEED WHEEL SPACER	
6	1	C	171D-116		AGITATOR	
5	1	B	171D-117		LOAD WHEEL	
4	1	B	171D-118		FEED WHEEL	
3	1	B	171D-115		LOAD WHEEL COVER	
2	1	D	171D-114		FEED WHEEL COVER	
1	1	D	171D-004		BASE PLATE BOTTOM ASSY	

UNLESS OTHERWISE SPECIFIED DIMENSIONS ARE IN INCHES TOLERANCES ARE: FRACTIONS DECIMALS ANGLES * .XX ± * .XXX ±			<b>BRIGS MACHINING COMPANY.</b> LAGUNA HILLS, CA	
MATERIAL FINISH NEXT ASSY: 171D-001 USED ON:			<b>BASE PLATE TOP ASSY</b> DRAWN BY: _____ CHECKED BY: _____ SIZE: <b>D</b> FSCM NO.: _____ DWG NO.: 171D-005 REV: 1 SCALE: 1/3 SHEET: 1 of 1	

APPLICATION	DO NOT SCALE DRAWING
-------------	----------------------