

**IMPORTANT**  
 THIS DRAWING OR SPECIFICATION CONSTITUTES THE CONFIDENTIAL INFORMATION OF BRIG'S MACHINING CO. AND ITS RECEIPT OR POSSESSION DOES NOT CONVEY ANY RIGHT IN OR LICENSE TO USE IT OR THE INFORMATION DISCLOSED HEREIN NOR ANY RIGHT TO REPRODUCE THIS DRAWING OR SPECIFICATION NOR ANY PART HEREOF WITHOUT THE WRITTEN CONSENT OF BRIG'S MACHINING CO.

ZONE		REV	DESCRIPTION	DATE	APPROVED

NOTES:

- A GREASE O-RING AND O-RING GROOVE WITH VACUUM GREASE BEFORE ASSEMBLING TOGETHER
- B INSERT ITEM 6 INTO ITEM 3
- C LINE UP GROOVE ON DRIVE PIN WITH SET SCREW

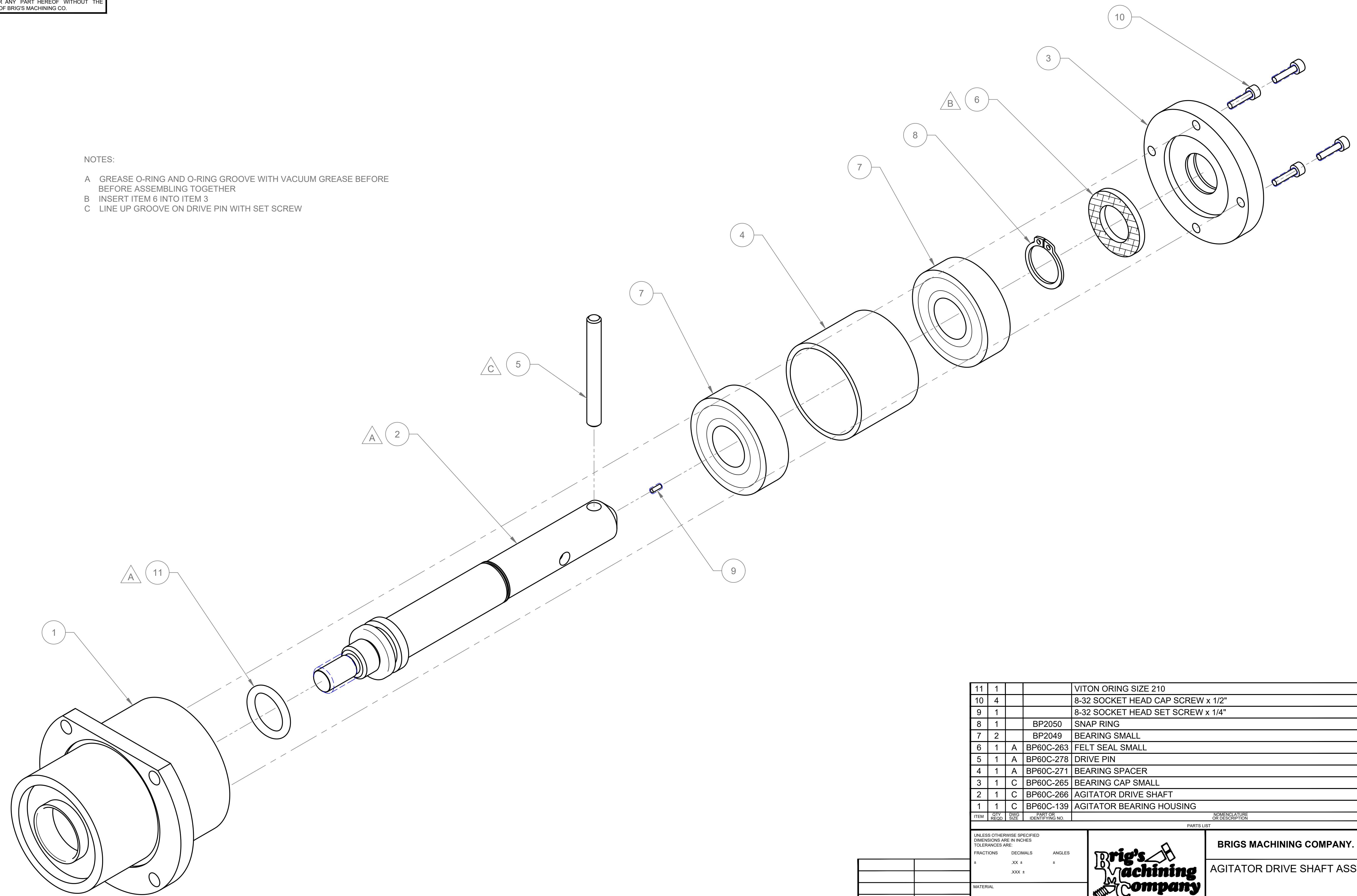

ITEM	QTY	DWG	PART OR	NOMENCLATURE	MATERIAL
REQD	SIZE	IDENTIFYING NO.	OR DESCRIPTION	SPECIFICATION	
11	1			VITON O-RING SIZE 210	
10	4			8-32 SOCKET HEAD CAP SCREW x 1/2"	
9	1			8-32 SOCKET HEAD SET SCREW x 1/4"	
8	1		BP2050	SNAP RING	
7	2		BP2049	BEARING SMALL	
6	1	A	BP60C-263	FELT SEAL SMALL	
5	1	A	BP60C-278	DRIVE PIN	
4	1	A	BP60C-271	BEARING SPACER	
3	1	C	BP60C-265	BEARING CAP SMALL	
2	1	C	BP60C-266	AGITATOR DRIVE SHAFT	
1	1	C	BP60C-139	AGITATOR BEARING HOUSING	

UNLESS OTHERWISE SPECIFIED DIMENSIONS ARE IN INCHES TOLERANCES ARE:			<b>BRIGS MACHINING COMPANY.</b> LAGUNA HILLS, CA	
FRACTIONS	DECIMALS		<b>AGITATOR DRIVE SHAFT ASSY</b>	
+	.XX ±			
	.XXX ±			
MATERIAL	FINISH	DRAWN BY	SIZE	FSCM NO.
			D	
NEXT ASSY	USED ON	CHECKED BY	DWG NO.	REV
			BP60C-009	1
APPLICATION	DO NOT SCALE DRAWING	SCALE	1/1	SHEET 1 of 1